

FAN CONFIGURATION:

Nº of fans: 1
Motor type: EC (Electronically Commuted)
Max. energy consumption: 0,169kW
Power requirements: 230V/50-60Hz
Max. input current: 1,35A
Impeller: Diam. 190 mm-Centrifugal backward curved

FILTER CONFIGURATION:

Particle filter: ePM2,5 ≥65% (ISO 16890) / F7 (EN779)
Gas & odor filter: GRSystem 2
Absolute filter: HEPA H14 (EN1822) with virucidal nanofibres

- All frame filters in galvanized steel
- Absolute filter with individual number and test report

GENERAL SPECIFICATIONS:

- Dimensions: H 593 x W 553 x D 725 mm
- Box dimensions: H 560 x W 600 x D 800 mm
- Net weight: 50Kg / Gross weight: 51Kg

FEATURES:

- Plug & Play, portable device with wheels
- Digital flow controller, 90 levels (10 to High)
- Electrical power cord IEC C14
- Air intake with finger guard, air impulsion drive through rotational diffuser
- Front wheels with brakes

PERFORMANCE:

- Air delivery certified (tested with all filters installed)
- Leak tested (individually tested with all filters installed)

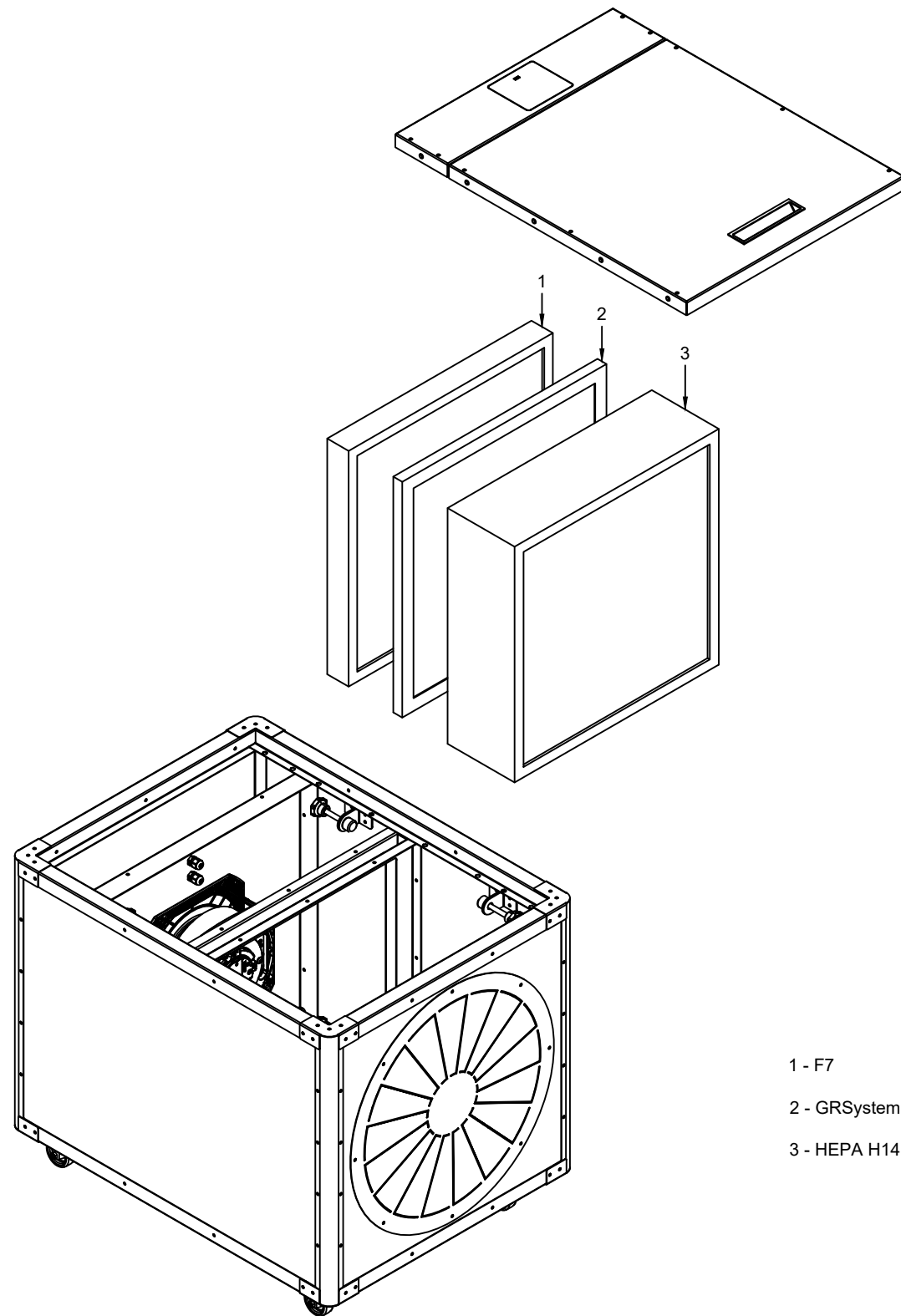

- 1 - F7
- 2 - GRSystem 2
- 3 - HEPA H14

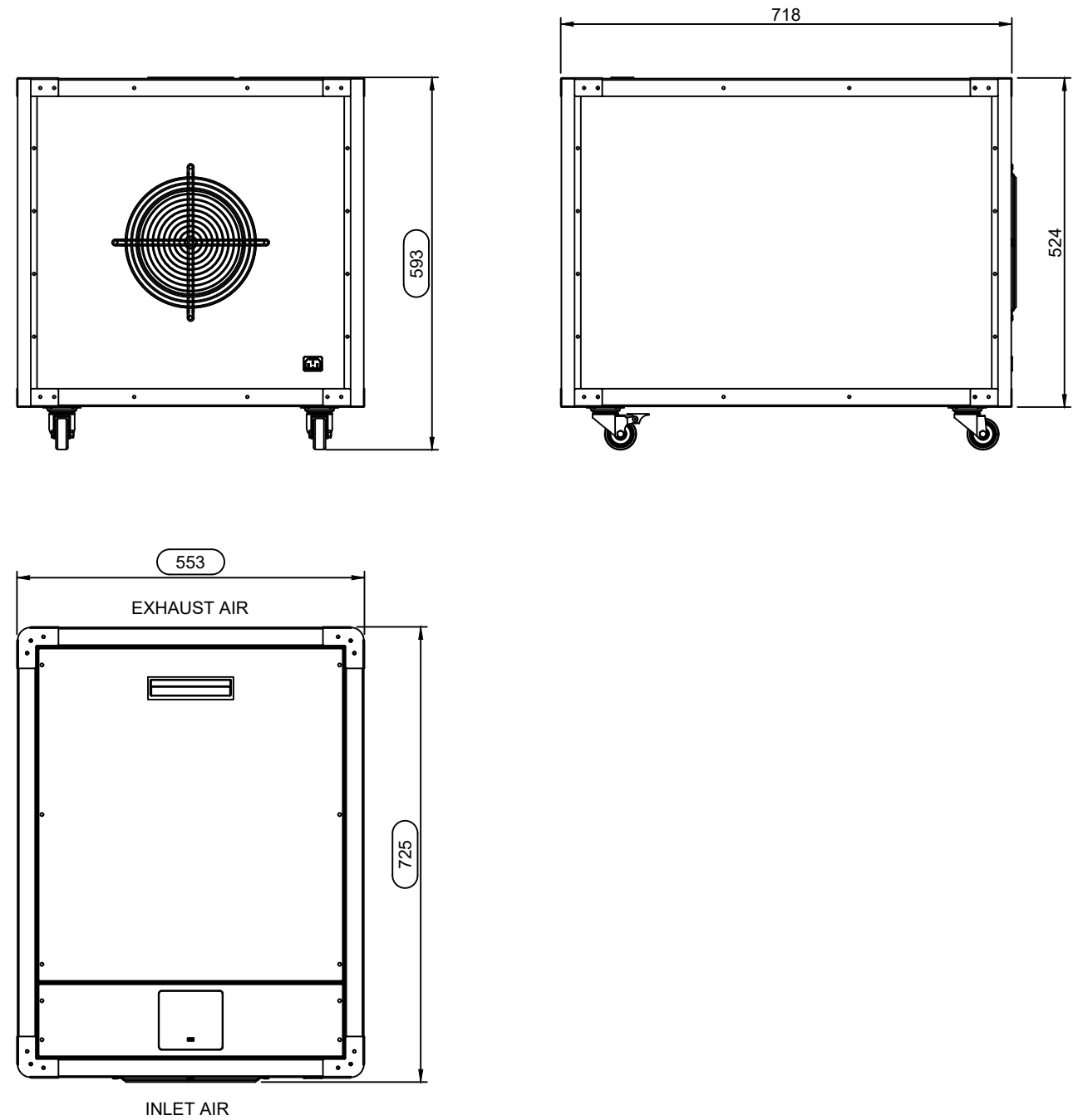

Nivel	10	20	30	40	50	60	70	80	90	Hi
Air Flow (m3/h)	70	120	190	250	300	350	400	480	550	600
Lp (3m) dB(A)	13,6	16,9	23,9	29,9	35,1	39,4	44,2	48,1	51,1	51,5

NOTES:

1- The filter maintenance is performed through the top panel of the unit.

Date: 16/02/2022

Drawing for: LE

Checked: SL

Din-A3
Escala: 1:10

Model: AIR+ 600

Version: V.03

Product code: VTPB600000001

